

Product Information

Sensors and Instrumentation

**Flow Indicator/
Switch NJ / NJV**



- Scale for various viscosities or viscosity stabilised from 30 to 200 mm²/s
- Also for dark or dirty media
- Robust construction

Characteristics

Mechanical flow meter with spring-supported piston for fluid media. The measured value is transferred to a display ring via a magnetic coupling. Because of this separation, the display cannot become dirty. Robust construction in brass or stainless steel.

Technical data

Switch	optional reed switch	
Nominal width	DN 8..25	
Process connection	female thread G 1/4..G 1 (further process connections available on request)	
Display range	2..80 l/min	for details see table "Ranges"
Q_{max.}	to 80 l/min	
Tolerance	±8 % of the full scale value, minimum 1 l/min	
Pressure resistance	PN 100 bar	
Media temperature	-20..+100 °C	
Ambient temperature	-20..+70 °C	
Media	water (NJ only), oils (aggressive media available on request)	
Wiring	for options, see "Switch contact options"	
Switching voltage		
Switching current		
Switch performance		
Protection class		
Protection class		
Electrical connection		
Materials medium-contact	<i>Brass construction:</i> CW614N nickelled, CW614N, 1.4310, hard ferrite, NBR	<i>Stainless steel construction only with NJ:</i> 1.4571, 1.4310, hard ferrite PTFE-coated, FKM

Non-medium-contact materials	Acrylic HS
Weight	see table "Dimensions and weights"
Installation location	Standard: Vertical inwards flow from below; other installation positions are possible; the installation position affects the switching point and range.

Ranges

Details in the table correspond to horizontal inwards flow with increasing flow rate.

Standard NJ

G	Display range l/min H ₂ O	Q _{max.} recommended	Types
G 1/4	2 - 10	10	NJ-008G.010
G 3/8	4 - 20	20	NJ-010G.010
	10 - 40		NJ-010G.020
G 1/2	2 - 10	40	NJ-015G.010
	4 - 20		NJ-015G.020
	10 - 40		NJ-015G.040
G 3/4	2 - 10	60	NJ-020G.010
	4 - 20		NJ-020G.020
	10 - 40		NJ-020G.040
G 1	2 - 10	80	NJ-025G.010
	4 - 20		NJ-025G.020
	10 - 40		NJ-025G.040
	20 - 80		NJ-025G.080

Special ranges are available.

Multi-scale display ranges

1	20-45	75-120	180-250	mm ² /s
2 - 10	0.6 - 8	0.2 - 7	0.1 - 4	l/min
4 - 20	2.0 - 19	1.0 - 17	0.5 - 15	
10 - 40	7.0 - 38	6.0 - 37	4.0 - 36	
20 - 80	19.0 - 73	17.0 - 68	13.0 - 63	

Viscosity stabilised NJV

Viscosity compensated devices are measured in the factory as per ISO VG100.

G	Display range l/min oil 30..200 mm ² /s	Q _{max.} recommended	Types
G 1/4	2 - 10	10	NJV-008G.010
G 3/8	4 - 20	20	NJV-010G.010
	10 - 40		NJV-010G.020
G 1/2	2 - 10	40	NJV-015G.010
	4 - 20		NJV-015G.020
	10 - 40		NJV-015G.040
G 3/4	2 - 10	60	NJV-020G.010
	4 - 20		NJV-020G.020
	10 - 40		NJV-020G.040
	10 - 60		NJV-020G.080
G 1	2 - 10	80	NJV-025G.010
	4 - 20		NJV-025G.020
	10 - 40		NJV-025G.040
	10 - 60		NJV-025G.080

Special ranges are available.

Product Information

Sensors and Instrumentation

Dimensions and weights

G	Types	Weight kg		
		without switching head NJ- / NJV-	With switching head Plastic NJK / NJVK	with metal switching head NJM / NJVM
G 1/4	...-008G....	1.5	1.65	1.95
G 3/8	...-010G....	1.4	1.55	1.85
G 1/2	...-015G....	1.3	1.45	1.75
G 3/4	...-020G....			
G 1	...-025G....	1.2	1.35	1.65

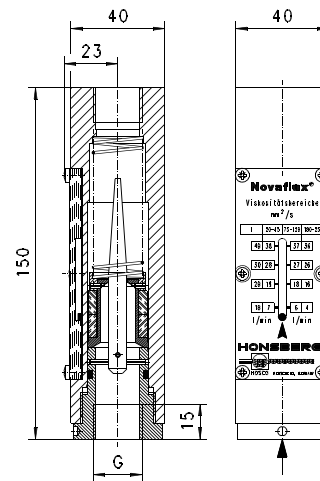

Switch contact options

Plastic switch contacts

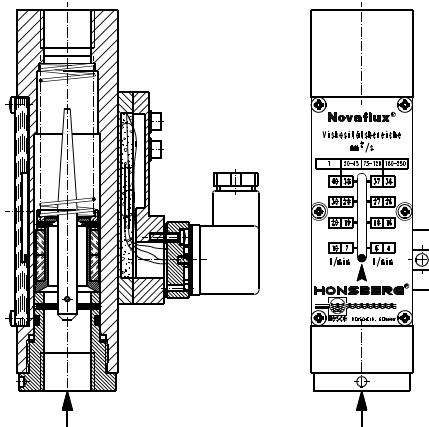

Switch contact K1

Wiring	maker no. 0.338 diode green	
Switching voltage	max. 250 V AC	
Switching current	max. 0.5 A	
Switch performance	max. 10 VA	
Protection class	2 - safety insulation	
Ingress protection	IP 65	
Electrical connection	DIN 43650-A plug	
Non-medium-contact materials	PA	
Additional weight	0.2 kg	

Switch contact K2

Wiring	normally open (n.o.) no. 0.445	
Switching voltage	max. 250 V AC	
Switching current	max. 0.5 A	
Switching capacity	max. 10 VA	
Protection class	2 - safety insulation	
Ingress protection	IP 65	
Electrical connection	DIN 43650-A plug	
Non-medium-contact materials	PA	
Additional Weight	0.2 kg	

Switch contact K3

Wiring	changeover no. 0.347	
Switching voltage	max. 24 V DC	
Protection class	2 - safety insulation	
Ingress protection	IP 65	
Electrical connection	plug Hirschmann G 4	
Non-medium-contact materials	PA	
Additional weight	0.2 kg	

Product Information

Sensors and Instrumentation

Switching contacts made of metal

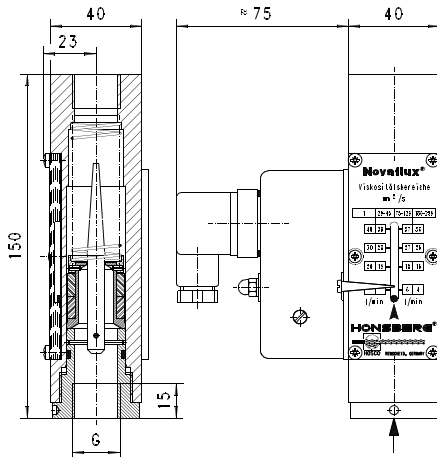

Switch contact M1

Wiring	no. 0.333 yellow beige blue brown black <p>Attention! Only hood is earthed, not the body of the flow indicator</p>
Switching voltage	max. 250 V AC
Switching current	max. 5 A
Supply voltage	230 V AC, optionally 125 V AC, 24 V DN (10 mA)
Protection class	1 - PE connection
Ingress protection	IP 65
Electrical connection	cable 2.5 m
Non-medium-contact materials	steel, rilsan-coated, PA
Additional weight	0.35 kg

Switch contact M2

Wiring	normally open (n.o.) no. 0.215 blue brown
Switching voltage	max. 250 V AC
Switching current	max. 0.5 A
Switch performance	max. 10 VA
Protection class	1 - PE connection
Ingress protection	IP 65
Electrical connection	cable 2.5 m
Non-medium-contact materials	steel, rilsan-coated, PA
Additional weight	0.3 kg

Attention! Only hood is earthed, not the body of the flow indicator

Product Information

Sensors and Instrumentation

Handling and Operation

Note

- Include straight calming section of 5 x DN in inlet and outlet.
- If the media are dirty, install a filter (use magnetic filter for ferritic components).
- It must be ensured that the values given for voltage, current, and power are not exceeded.
- When switch on, a load must be connected in series.
- The electrical details apply to ohmic loads. Capacitive, inductive and lamp loads must be operated using a protective circuit.

Adjustment

If it is necessary to set the switching value, the switching head can be adjusted lengthways. When the switching value is reached, the switch contact is fixed in place by fastening bolts.

Ordering code

1. 2. 3. 4. 5. 6
 G

○=Option

1. Construction		
NJ	standard	
NJV	viscosity compensated	
2. Switching contact		
-	without switch contact	
K1-	with switch contact K1 - wiring 0.338	
K2-	○ with switch contact K2 - wiring 0.445	
K3-	○ with switch contact K3 - wiring 0.347	
M1-	○ with switch contact M1 - wiring 0.333	
M2-	○ with switch contact M2 - wiring 0.215	
3. Nominal width		
008	DN 8 - G 1/4	
010	DN 10 - G 3/8	
015	DN 15 - G 1/2	
020	DN 20 - G 3/4	
025	DN 25 - G 1	
4. Process connection		
G	female thread	
5. Connection material		
M	brass	
K	○ stainless steel	
6. NJ - display range H₂O for vertical inwards flow		
010	2 - 10 l/min	●
020	4 - 20 l/min	●
040	10 - 40 l/min	●
080	20 - 80 l/min	●
NJV - display range oil 30..200 mm²/s for vertical inwards flow		
010	2 - 10 l/min	●
020	4 - 20 l/min	●
040	10 - 40 l/min	●
060	20 - 60 l/min	●

Options

- Special quantities/special scaling

Ordering information

- Specify direction of flow, medium, and display range.
- For viscous media specify viscosity, temperature, and medium (e.g. ISO VG 68) (enquire about display range).
- For gases, state pressure (relative or absolute), temperature and medium (e.g. air) (request display range).