

Product Information

**Level Switch
RW-015HKL**



- Temperature up to 200 °C
- Highly reproducible
- Normally open or normally closed contact

Characteristics

Mechanical level monitor for fluid media, with contact-free triggering of a reed contact.

Technical data

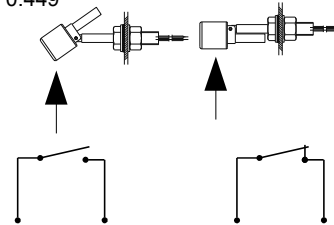
Switch	reed switch
Process connection	male thread 1/2 -13 THD
Density of medium	≥ 0.7 g/cm ³
Pressure resistance	PN 6 bar
Medium temperature	-20..+200 °C
Ambient temperature	-20..+70 °C
Media	water, oils (aggressive media available on request)
Wiring	'normally open' or 'normally closed' No. 0.449 
Switching voltage	max. 220 V AC
Switching current	max. 0.14 A
Switching capacity	max. 30 VA

Protection class	2 - safety insulation
Ingress protection	IP 65
Electrical connection	wiring 600 mm
Materials medium-contact	1.4571
Weight	0.12 kg
Installation location	horizontal installation

Dimensions

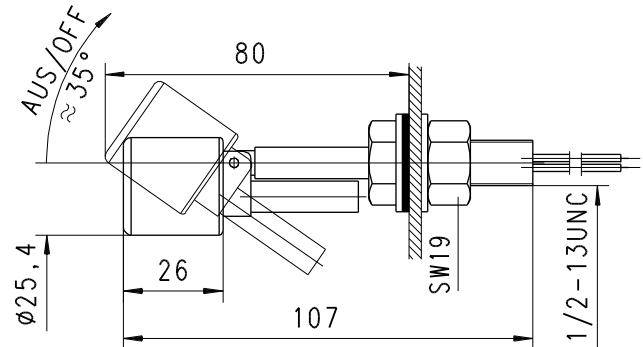

Handling and operation

- It must be ensured that the values given for voltage, current, and power are not exceeded.
- When switched on, a load must be connected in series.
- The electrical details apply to ohmic loads. Capacitive, inductive and lamp loads must be operated using a protective circuit.
- Not suitable for use in media with ferritic particles.

Ordering code

RW - 1. 015 2. H 3. K 4. L

1. Connection size	015	threaded connection 1/2 13UNC
2. Process connection	H	screw-in thread
3. Connection material	K	stainless steel
4. Electronic connection	L	wiring