

Flow Indicator MP-...GR



- No electrical supply required
- Insensitive to dirt
- Also for dark or dirty media
- Rotatable scale, easy to read
- No glass parts under load from pressure or media

Characteristics

The volume flow raises a disc against a spring force. Via a tappet, the disc actuates a magnet which is coupled to a hermetically sealed display ring.

Technical data

Switch/sensor	without	
Nominal width	DN 8..80	
Process connection	female thread G 1/4 ..G 3	
Range	1.5..600 l/min	for details see table "Ranges"
Q _{max.}	to 600 l/min	
Tolerance	±5 % of full scale value	
Pressure resistance	G 1/4..G 1/2 - PN 200 bar	
	G 3/4..G 1 - PN 25 bar	
	G 1 1/4 .. G 1 1/2 - PN 16 bar	
Medium temperature	-20..+100 °C	
Ambient temperature	-20..+70 °C	
Media	water (oils and gases available on request)	
Electrical data	none	
Materials medium-contact	Rg 5 / Rg 6 nickelled, CW614N, 1.4310, hard ferrite, NBR	
Non-medium-contact materials	Acrylic, CW614N, NBR	
Weight	see table "Dimensions and weights"	
Installation location	Standard: horizontal inwards flow; display downwards not recommended; other installation positions are possible; the installation position affects the switching point and range.	

Ranges

Details in the table correspond to horizontal inwards flow with increasing flow rate.

● = Standard ○ = Option

G	Nominal width		Display range l/min H ₂ O	Q _{max.} recommended	Types
G 1/4	DN 8	●	1.5 - 6	6	MP-008GR006
		○	2.5 - 10	10	MP-008GR010
G 3/8	DN 10	○	1.5 - 6	6	MP-010GR006
		●	2.5 - 10	10	MP-010GR010
G 1/2	DN 15	○	1.5 - 6	6	MP-015GR006
		○	2.5 - 10	10	MP-015GR010
		●	5.0 - 20	20	MP-015GR020
G 3/4	DN 20	○	2.5 - 10	10	MP-020GR010
		○	5.0 - 20	20	MP-020GR020
		●	10.0 - 40	40	MP-020GR040
G 1	DN 25	○	2.5 - 10	10	MP-025GR010
		○	5.0 - 20	20	MP-025GR020
		●	10.0 - 40	40	MP-025GR040
G 1 1/4	DN 32	○	12.0 - 60	60	MP-032GR060
		●	20.0 - 100	100	MP-032GR100
G 1 1/2	DN 40	●	30.0 - 150	150	MP-040GR150
		○			MP-050GR150
G 2	DN 50	○	50.0 - 250	250	MP-050GR250
		●			MP-065GR250
G 2 1/2	DN 65	○	80.0 - 400	400	MP-065GR400
		●			MP-080GR400
G 3	DN 80	○	120.0 - 600	600	MP-080GR600
		●			

Special ranges are available.

Dimensions and weights

G	Types	H	L	SW	X	Weight kg
G 1/4	MP-008GR...	130	68	29	12	1.1
	MP-010GR...					
	MP-015GR...				13	
G 3/4	MP-020GR...	133	73	32	11	1.2
G 1	MP-025GR...	136	87	41	12	1.4
G 1 1/4	MP-032GR...	150	98	52	13	2.0
G 1 1/2	MP-040GR...	154	113	59	14	2.6
G 2	MP-050GR...	184	137	72	17	4.2
G 2 1/2	MP-065GR...	200	160	85	26	5.6

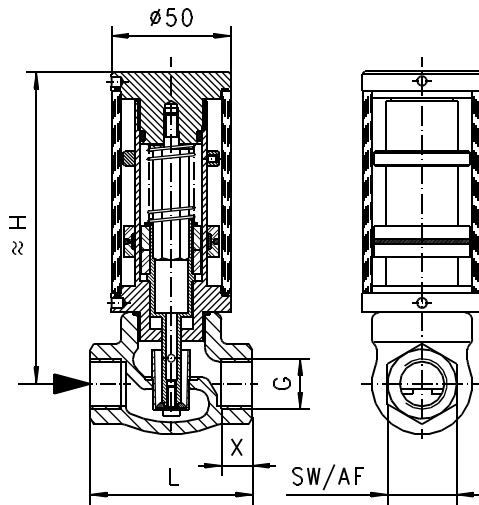

Handling and operation

Note

- Include straight calming section of 5 x DN in inlet and outlet.
- If the media are dirty, install a filter (use magnetic filter for ferritic components).
- Remove the transport lock (white plastic screw in acrylic body) before starting operation. Then seal the threaded hole with the sticker (included in the shipment).

Display

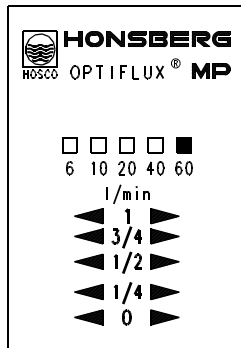

- The display is rotatable.

Ordering code

MP - 1. 2. 3. 4.
 G R

●=Standard ○=Option

1. Nominal width						
008	DN 8 - G 1/4					
010	DN 10 - G 3/8					
015	DN 15 - G 1/2					
020	DN 20 - G 3/4					
025	DN 25 - G 1					
032	DN 32 - G 1 1/4					
040	DN 40 - G 1 1/2					
050	DN 50 - G 2					
065	DN 65 - G 2 1/2					
080	DN 80 - G 3					
2. Process connection						
G	female thread					
3. Connection material						
R	red bronze					
4. Display range H ₂ O for horizontal inwards flow						
006	1.5 - 6 l/min					○ ○ ●
010	2.5 - 10 l/min					○ ○ ○ ● ○
020	5.0 - 20 l/min					○ ○ ●
040	10.0 - 40 l/min					● ●
060	12.0 - 60 l/min					○
100	20.0 - 100 l/min					●
150	30.0 - 150 l/min					○ ●
250	50.0 - 250 l/min					○ ●
400	80.0 - 400 l/min					○ ●
600	120.0 - 600 l/min					●

Options

- Housing made from stainless steel
- Special ranges/special scaling

Ordering information

- Specify direction of flow, medium, and display range.
- For oils. State viscosity, temperature and designation (e.g. ISO VG 68) (enquire about display range).
- For gases, state pressure (relative or absolute), temperature and medium (e.g. air) (request display range)