

**Product Information**

**FW4V-015GM**

**Flow Switch  
FW4V-015GM**

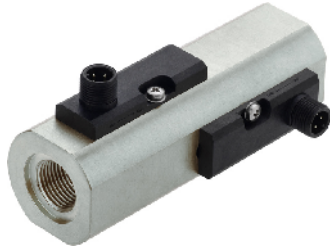

- Bidirectional flow switching
- Viscosity stabilised
- Compact design

**Characteristics**

Mechanical flow switch, for viscous media, with spring-supported piston and magnetic triggering of a reed switch.

**Technical data**

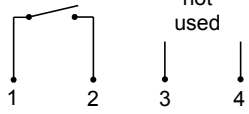
<b>Sensor</b>	reed switch
<b>Nominal width</b>	DN 15
<b>Process connection</b>	female thread G 1/2
<b>Switching point</b>	1 l/min the switching point is suitable for horizontally decreasing flows.
<b>Pressure loss</b>	8 bar at Q <sub>max.</sub>
<b>Q<sub>max.</sub></b>	10 l/min
<b>Tolerance</b>	±10 %
<b>Viscosity stability</b>	at 30..330 mm <sup>2</sup> /s ±10 %, min ± 0.5 l/min
<b>Pressure resistance</b>	PS 300 bar
<b>Media temperature</b>	-20 °C..+90 °C
<b>Ambient temperature</b>	-20 °C..+70 °C
<b>Media</b>	oils
<b>Wiring</b>	normally opened ( n.o.) No. 0.378 
<b>Switching voltage</b>	max. 230 V AC
<b>Switching current</b>	max. 0.5 A
<b>Switching capacity</b>	max. 50 VA
<b>Protection class</b>	2 - safety insulation
<b>Ingress protection</b>	IP 67
<b>Electrical connection</b>	for round plug connector M12x1, 4-pole
<b>Materials medium-contact</b>	CW614N nickelled, 1.4310, hard ferrite
<b>Non-medium-contact materials</b>	PC, 1.4305
<b>Weight</b>	0.95 kg
<b>Installation location</b>	Standard: horizontal inwards flow; other installation positions are possible; the installation position affects the switching point.

**Dimensions**

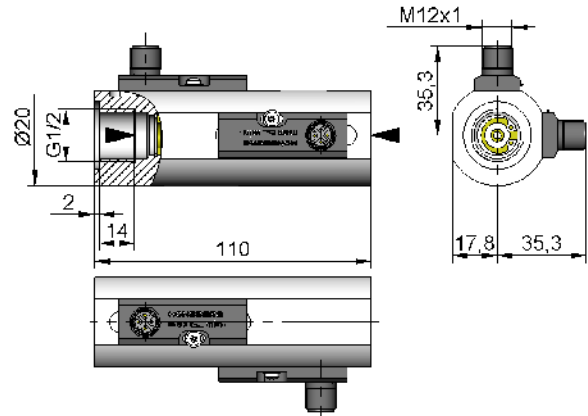

**Handling and operation**

**Note**

- Include straight calming section of 5 x DN in inlet and outlet.
- If the media are dirty, install a filter (use magnetic filter for ferritic components).
- It must be ensured that the values given for voltage, current, and power are not exceeded.
- When switch on, a load must be connected in series.
- The electrical details apply to ohmic loads. Capacitive, inductive and lamp loads must be operated using a protective circuit.

**Adjustment**

The setting of the switching points to 1 l/min is carried out in the factory.

**Ordering code**

FW4V - 1. 015 2. G 3. M 4. 001

<b>1. Nominal width</b>	015	DN 15 - G 1/2
<b>2. Process connection</b>	G	female thread
<b>3. Connection material</b>	M	brass
<b>4. Switching point H<sub>2</sub>O for horizontal inwards flow</b>	001	1 l/min

**Options**

- Special values
- Cable outlet 3 m

**Ordering information**

- Specify direction of flow, medium, and switching value .
- For viscous media specify viscosity, temperature, and medium (e.g. ISO VG 68) (enquire about switching range).